

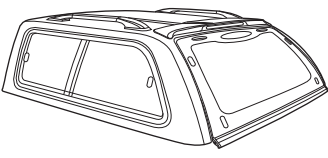

<p>1 HARDTOP 1 SET.</p> 	<p>2 KWIC KLAMP S4 6 SET</p> 	<p>3 LATCH STL.S-5 P/L 2 SET</p> 	<p>4 RUBBER TRUCK EDGE 1 PC.</p> 
---	---	--	---

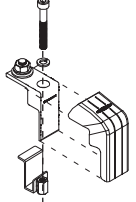

3

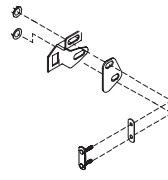

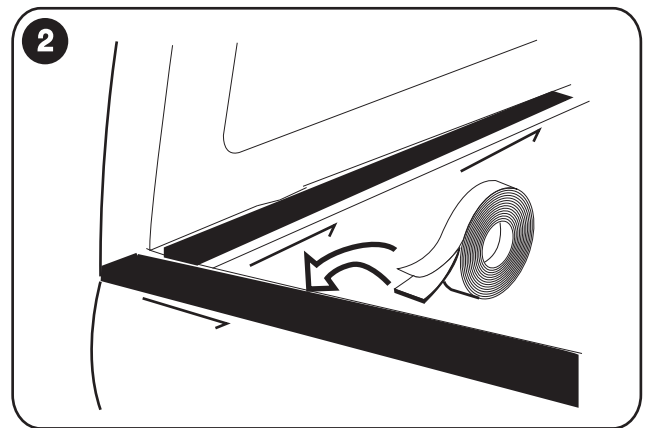
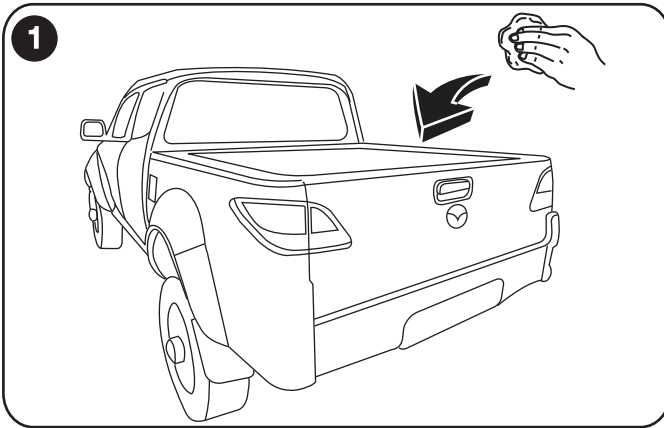
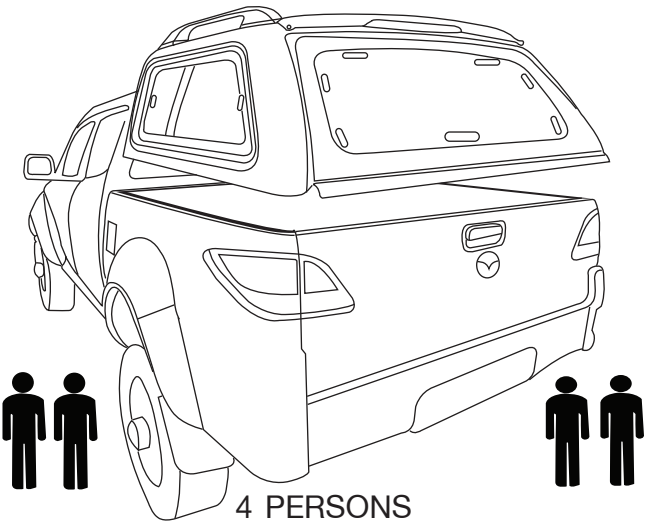
4 PERSONS

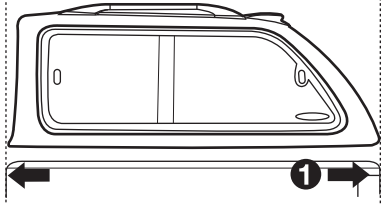
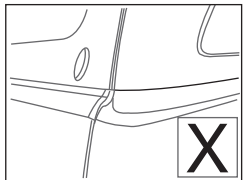
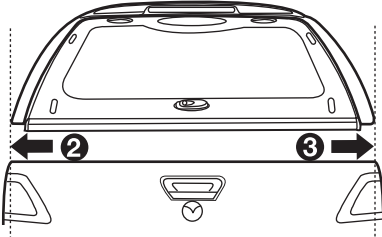
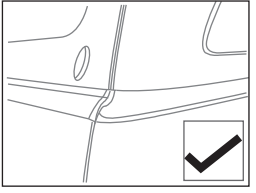
 <p>1</p>	
 <p>2 3</p>	

4 FOR 6 POSITIONS

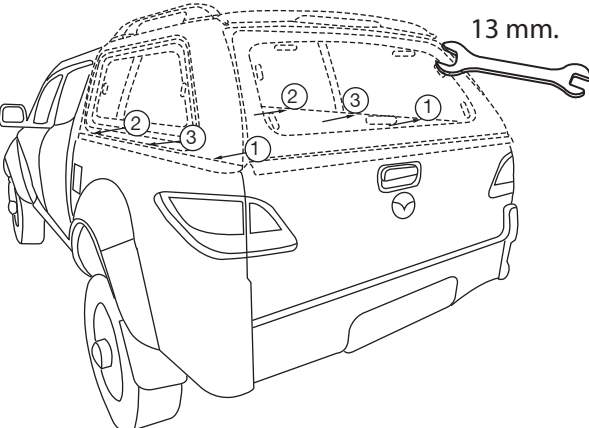

13 mm.

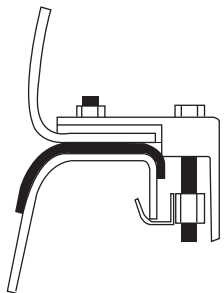

Hole saw cut line

Inner lower edge line

Ø 20

HOLE SAW Ø 20

In case of having bed liner , the bed liner must be drilled with a hole saw 20 mm. at the same level of truck's inner low edge



7 Nm

